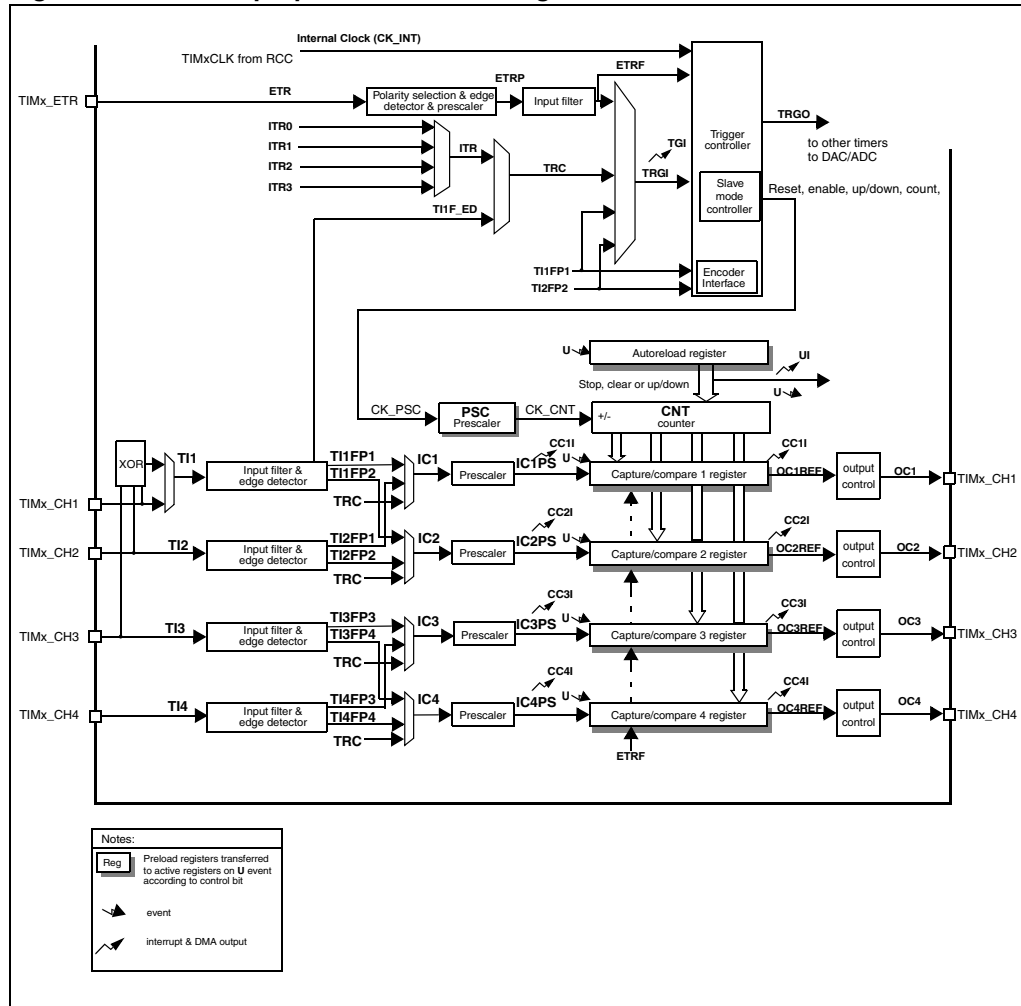

Figure 160. General-purpose timer block diagram



## 17.3 TIM2/TIM3/TIM4 functional description

### 17.3.1 Time-base unit

The main block of the programmable timer is a 16-bit/32-bit counter with its related auto-reload register. The counter can count up, down or both up and down but also down or both up and down. The counter clock can be divided by a prescaler.

The counter, the auto-reload register and the prescaler register can be written or read by software. This is true even when the counter is running.

The time-base unit includes:

- Counter Register (TIMx\_CNT)
- Prescaler Register (TIMx\_PSC):
- Auto-Reload Register (TIMx\_ARR)